

LUX

D811035 02-10-00 Vers. 02



HYDRAULIC AUTOMATION FOR SWING GATES



Thank you for buying this product. Our company is sure that you will be more than satisfied with the product's performance.

Carefully read the "WARNINGS" pamphlet and the "INSTRUCTION BOOKLET" which are supplied together with this product, since they provide important information regarding the safety, installation, use and maintenance of the product. This product complies with recognised technical standards and safety regulations. We declare that this product is in conformity with the following European Directives: 89/336/EEC, 73/23/EEC (amended by RL 91/263/EEC, 92/31/EEC and 93/68/EEC), (amended by RL 96/68/EEC).

1) GENERAL OUTLINE

A compact, sturdy oleodynamic piston, available in a wide range of models to fit any need and field of operation. It is available in versions both with or without (reversible) hydraulic lock, that need to be equipped with an electric lock to hold the gate both closed and open.

The emergency release is obtained with the special key provided.

The adjustment of the pushing force is extremely precise and is performed by means of two by-pass valves that act as an antisquash safety. The operation at the end of the stroke is controlled electronically by a timer in the control panel.

The LUX series includes special versions with slowdown in the closing phase (LUX R) while the LUX FC series is especially suited to areas prone to heavy snowfalls or where the central gate stop cannot be provided (see specific instruction manual).

TABLE 1

Mod.	Type of lock	Pump l/min	Working time (s)	Max. wing length / weight (m) (kg)	Stroke working / tot (mm) (mm)	Manoeuvres 24h
LUX	electric lock	1,2	17	2 300	270 290	500
LUX B	hydraulic closing	1,2	17	2 300	270 290	500
LUX 2B	hydraulic clos. - open.	1,2	17	2 300	270 290	500
LUX L	electric lock	0,6	33	2-4 300/500	270 290	350
LUX G	electric lock	0,6	48	5-2 300/800	390 410	250
LUX GV	electric lock	1,2	28	3,5 300	390 410	500

2) THE MAIN PARTS IN THE AUTOMATION (fig. 1)

M) Single phase 2 pole motor protected by thermal circuit breaker

P) Hydraulic lobe pump

D) Fluid distributor with adjustment valves

C) Cylinder with piston

Standard components:

- gate post and gate brackets - release key and bypass adjustment
- drive capacitor - instruction booklet.

3) TECHNICAL SPECIFICATIONS

Power supply :230V ±10% - 50 Hz (*)

Motor :2800 min⁻¹

Power absorption :250W

Capacitor :6.3 µF

Current absorption :1.4A

Max. pressure :30 bar

Pump delivery :See Table 1

Pushing force :3000N

Pulling force :2600 N

Working stroke :See Table 1

Impact reaction :hydraulic clutch

Manual manoeuvres :by release key

Max. no. manoeuvres in 24h :See table 1

Thermal protection :160° C

Ambient temperature :-10° C ÷ 60° C

Protection :IP 57

Controller weight :8.7 kg

Dimensions :see fig. 2

Circuit oil :idrolux

(*) Special voltages on request

4) INSTALLATION OF THE ACTUATOR

4.1) Preliminary checks

Check:

- that the structure of the gate is rigid and strong enough. In any case, the actuator must push against a reinforced point in the leaf
- that the leaves move manually without excessive effort for the whole of their stroke
- that the door stops are mounted on the leaves
- If the gate being installed is not new, check whether its components are worn.
Repair or replace any worn or damaged parts.

Automation reliability and safety are directly influenced by the condition of the gate's structure.

4.2) Installation values

The values to be known for installation can be found in the table related to the model being installed (fig. 3-4), with reference also to the diagram in fig. 5.

The diagram in fig. 5 uses the following legend:

P Gate-post fastening rear bracket

F Leaf fastening front fork

a-b "P" bracket installation values

C Distance between fixing points (see fig. 2)

D Gate length

X Distance from gate axis to the edge of the post

Z always over 45 mm (b - X)

kg max. weight of leaf (Table 1)

a° leaf opening in degrees

4.3) How to read the installation dimensions (fig. 3-4)

From the tables (fig. 3-4), select "a" and "b" according to the angle in degrees a° that the gate has to open. Each table shows the ideal value for "a" and "b" for an opening of a° = 90° at constant speed.

In this condition, the sum of "a" plus "b" gives the value of the working stroke "Cu" (fig. 2).

If there is too large a difference between "a" and "b", the leaf will not travel smoothly and the pushing or pulling force will fluctuate during its stroke.

When "a" and "b" are at their maximum, the piston develops the maximum force. This condition is particularly useful for heavy gates or gates with very

long leaves.

WARNING! The LUX models having a rod with adjustment ball joint enable the rod to be lengthened or shortened by about 6 mm., but only if it is set in the position shown in fig. 9 before being installed. When installed, this adjustment will allow for correcting the stroke of the rod. Fig. 11 shows the oscillation to which the LUX models with front and rear joint are subject with respect to the horizontal axis.

4.4) Off-standard installations

Fig. 6 - need for a recess to house the controller

when the leaf is completely opened;

Fig. 6 gives the size of the recess for the different LUX models.

Fig. 7 - if the "a" value is higher than the values listed in the installation tables, the leaf's hinge pivot should be shifted, or a recess be made in the gate-post (fig. 8).

4.5) Mounting the brackets to the gate-post and to the gate-leaf.

Fix the bracket "P" (fig. 10) to the gate-post with a good welding.

The fork "F" should be welded in the same way to the gate leaf along the distance "C" as shown in fig. 5, taking care that the actuator is perfectly horizontal (level "L" fig. 10) to the line of travel of the gate.

- If the gate-post is in brick, the plate "PF" must be welded to a metal base (mod. PLE) and set soundly into the post using adequately sized cramps "Z" welded to the back of the plate (fig. 12).

- If the gate-post is in stone, the plate "PF" welded to a metal base (mod. PLE) can be fixed with four metal expansion plugs "T" (fig. 13). If a larger gate is being installed it would be better to weld the plate "PF" to an angular base (fig. 14).

5) GROUND GATE STOPS

For the controller to operate correctly the gate stops "F" must be used both in opening and closing, as shown in fig. 15.

The gate stops should prevent the rod of the actuator from reaching its end of stroke. Fig. 16 gives the values which ensure a perfect installation when the actuator is performing the pushing or pulling function. They must be placed so that about a 5-10 mm margin of travel is maintained in the rod. This margin prevents any malfunctions.

6) FITTING THE ELECTRIC LOCK

This is only necessary on models without a hydraulic lock at closing end of stroke.

The electric lock mod. **EBP** (fig. 17) consists of a continuous electromagnet with ground catch. As long as the gearmotor is operating, this device features a non-stop excitation and maintains the bolt "D" lifted until it reaches the closing end of stroke without creating any friction. This characteristic enables the pushing force to be reduced in closing which will improve the antisquash safety level.

7) MOUNTING THE CABLE-CLAMP (fig. 18)

WARNING! Fix the board "B" to the base "F" with the screws "V" provided. Place the rubber "G" in its seat in the board "B". Slide the nut "D" onto the power cable and pass the cable over board "B" as shown in the picture Tighten

nut "D" until the power cable is clamped.

N.B. The board "B" can be fitted onto both the right and left of the base "F", as required (see picture).

The bottom of board "B" has a spiralled recess to eventually receive a spiralled sheath "GS" in PVC ($\varnothing = 12$).

8) THE ELECTRICAL PLANT SET-UP

Set the electrical plant (fig. 19) according to the current standards for electrical plants (CEI 64-8, IEC364, Harmonization HD384 and other national regulations. Keep the power supply connections definitely separated from the auxiliary connections (photocells, rubber skirts, control devices, etc.).

WARNING: For the power supply connection, use a multipolar cable with a $3 \times 1 \text{ mm}^2$ minimum section as prescribed by the above mentioned standards (for example, a H07RN-F cable with $3 \times 1 \text{ mm}^2$ section).

Perform the connections of the control and safety devices in compliance with the above mentioned standards.

Fig. 19 indicates the number of connections and the sections for 100 m. long power supply cables. For distances of over 100 m., calculate the cable section depending on the automation actual load. If the length of the auxiliary connections exceeds 50 metres or if they pass through critical areas subject to disturbances, we advise to disconnect the control and safety devices with suitable relays.

8.1) Automation main components (fig. 19)

l) Type approved omnipolar switch with 3 mm min. contact opening, provided with overload and short-circuit protection, used to break the automation connection from the mains. If not present, provide the automation with a type approved differential switch with adequate capacity and a 0.03 A threshold.

Qr) Control unit with built-in receiver

SPL) Pre-heating board for operation at temperatures below 5°C (optional)

S) Key selector

AL) Blinker tuned in with antenna and RG58 cable

M) Actuator

Fte) Pair of outside photocells (transmitters)

Fre) Pair of outside photocells (receivers)

Fti) Pair of inside photocells with CF column (transmitters)

Fri) Pair of inside photocells with CF column (receivers)

T) 1-2-4 channel transmitter

IMPORTANT: Before operating the actuator electrically, unscrew the bleeder screw "S" (fig. 20) found under the joint block and keep it for future uses. Remove the bleeder screw "S" only after having installed the actuator.

9) ADJUSTING THE PUSHING FORCE

The adjustment is made by two valves marked "close" and "open" which control the pushing force during closing and opening respectively.

By turning the valves towards "+", the force is increased, while by turning them towards "-" it is reduced.

To ensure an adequate antisquash safety, the pushing force must be adjusted to just over the push needed to move the leaf, both in closing and opening. In any event, the pushing force at the end of the leaf, must not exceed the limits prescribed by current national regulations. For no reason should the adjustment valves (bypass) be fully closed.

The actuator does not have electric limit switches. Therefore the motors stop when the working time set in the control unit has expired. The time set must be increased by 2-3 sec.'s with respect to the time in which the leaves reach the ground gate stops.

10) MANUAL OPENING

10.1) Versions with hydraulic lock

In case of emergency, for example during a power cut, the gate can be released by inserting the same key "C" used to adjust the bypass valve into the triangular pivot "P" found under the actuator (fig. 21) and turning it anti-clockwise. The gate can then be opened manually following the same speed as an automatic opening.

To restore the actuator to electrical operation, turn the key clockwise until pivot "P" is locked.

10.2) Versions without hydraulic lock

It is sufficient to open the electric lock with its key and move the leaf manually.

11) COVER POSITIONS

WARNING: In the LUX G models, it may be necessary to add a 25 mm lining under the fork "F" (fig. 23) to avoid any collision during the movement. The "C" cover of all LUX models can be changed from right to left by inverting the position of the cap "T" (fig. 24).

To fit the bypass guard (fig. 25), place it in position and insert it under the rod cover "C".

12) CHECKING THE AUTOMATION

Before considering the automation completely operational, the following checks must be made with great care:

- Check that all the components are firmly anchored.
- Control that all the safety means work properly (i.e. photocells, pneumatic skirt, etc.).
- Check the emergency manoeuvre control.
- Check the opening and closing manoeuvres using the controls.
- Check the control unit's electronic logic in normal (or customised) operation.

13) USE OF THE AUTOMATION

Since the automation may be remote controlled either by radio or a Start button, it is essential that all safeties are checked frequently.

Any malfunction should be corrected immediately by a qualified specialist. Keep children at a safe distance from the field of action of the automation.

14) THE CONTROLS

The controls can come in various forms (i.e. manual, remote controlled, limited access by magnetic badge, etc.) depending on needs and installation characteristics. For details on the various command systems, consult the specific instruction booklets.

Anyone using the automation must be instructed in its operation and controls.

15) MAINTENANCE

All maintenance on the controller must be performed with the system's power supply shut off.

- Check periodically for oil leaks. To top-up the oil proceed as follows:
 - a) Screw in the bleeder screw (fig. 20) and remove the controller from the gate.
 - b) Push the rod right back.
 - c) Set the controller upright and unscrew the cap O (fig. 18).
 - d) Use the same type of oil to top up the level until the motor bearing under the cap "O" is covered.
 - e) Close the cap "O" and mount the controller back onto the gate.
 - f) Remove the bleeder screw.
 - g) Run through 2 complete manoeuvres collecting the excess oil from the bleeder.
- Check the safety elements on the gate and drive unit.
- For any malfunction that remains unsolved, shut off the power to the system and call a qualified specialist (the installer). During a breakdown, use the manual release to allow the gate to be opened and closed by hand.

16) TROUBLE SHOOTING

16.1) Faulty operation of the gearmotor

- Use a suitable instrument to check if there is a voltage across the gearmotor terminals when an open or close command has been given
- If the motor vibrates but does not turn, this may be due to:
 - the common wire C is wrongly connected (it is always light blue)
 - the drive capacitor is not connected to the two drive terminals
 - if the leaf moves in the wrong direction, invert the drive connections of the motor in the control unit

LEAF STOP: when the operating time set in the control unit is too short, the leaves may not have time to complete their stroke. Slightly raise the operating time in the control unit.

16.2) Faulty operation of the electrical accessories

If any of the control and safety components are faulty, this can cause malfunctions or a breakdown of the whole automation.

If the control unit is equipped with a self-diagnostics system, identify the fault. In case of a fault, it is wise to disconnect each of the components in the automation one at a time, until the one that is causing the fault is found. After having repaired or replaced it, restore all the components that were disconnected. For details on each component, refer to its specific instruction manual.

WARNING: Any malfunction should be corrected immediately by a qualified specialist. When carrying out maintenance operations, the area around the gate should be well marked and barred in order to prevent accidents to people, animals and objects.

WARNINGS:

Trouble-free operation of the controller can only be guaranteed if the data given in this manual is respected.

The manufacturer is not liable for damages caused by the failure to respect safety rules, installation recommendations and instructions given in this manual.

Fig. 1

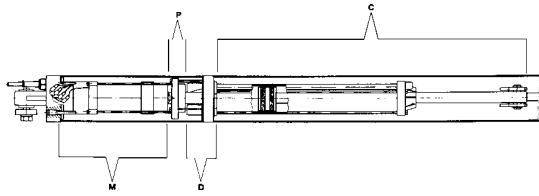

Fig. 2

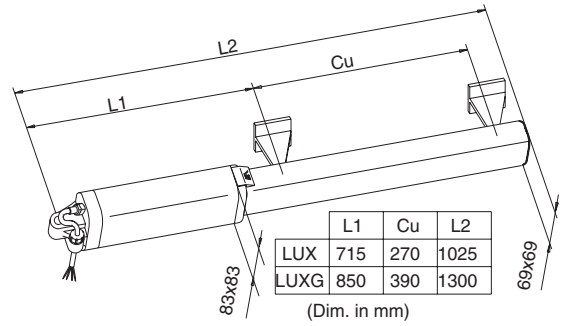

Fig. 3

mod. LUX						
a \ b	105	115	125	145	155mm	
105			113	104	99	
115		120	106	99	94	
125		109	100	94	90	
145	116	101	94			
155	95	89				

Fig. 4

mod. LUX G - LUX GV		(mm)									
a \ b	95	115	135	155	175	195	215	235	255	275	295
95											
115											
135											
155											
175											
195											
215											
235											
255											
275											
295											

Fig. 5

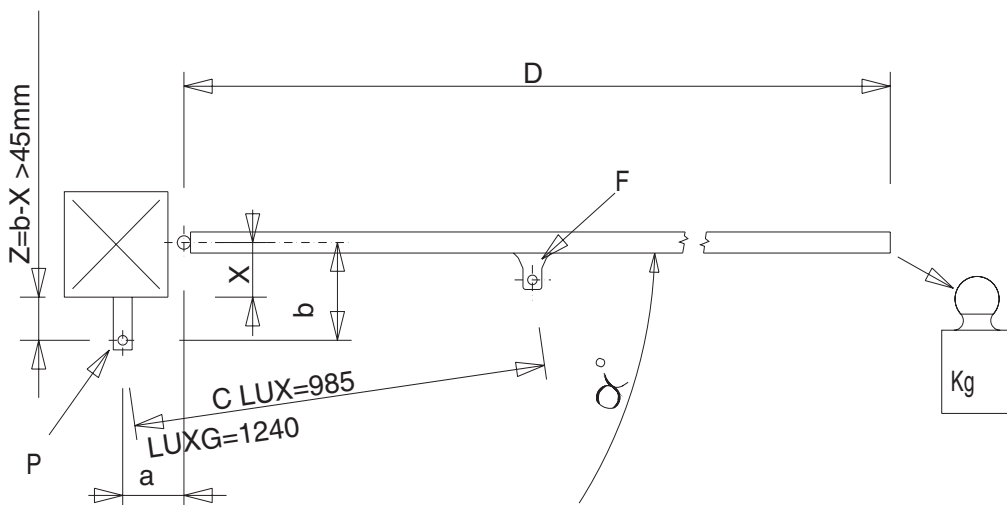

Fig. 6

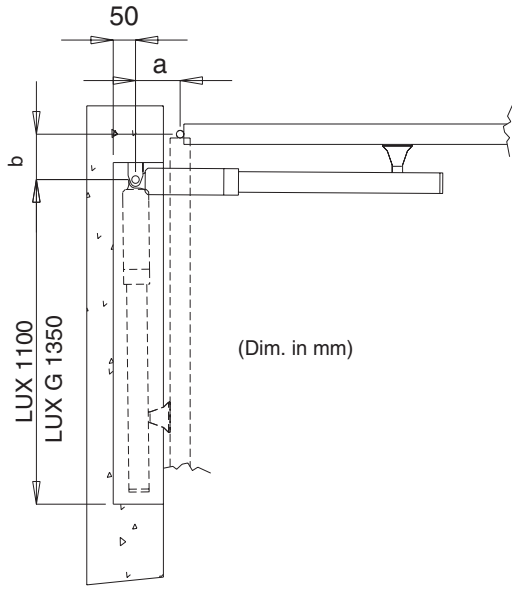

Fig. 7

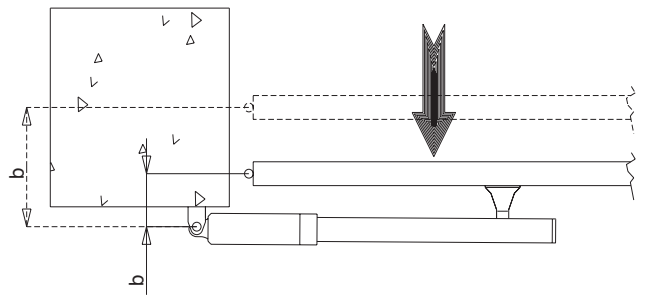

Fig. 8

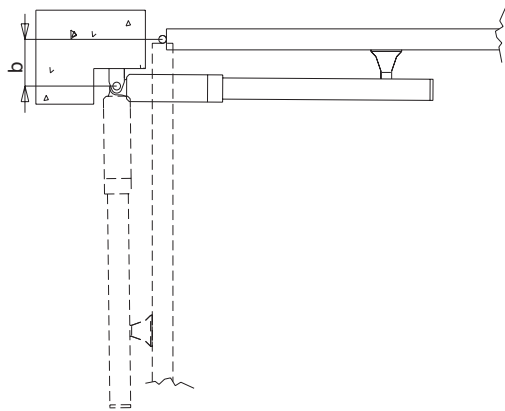

Fig. 9

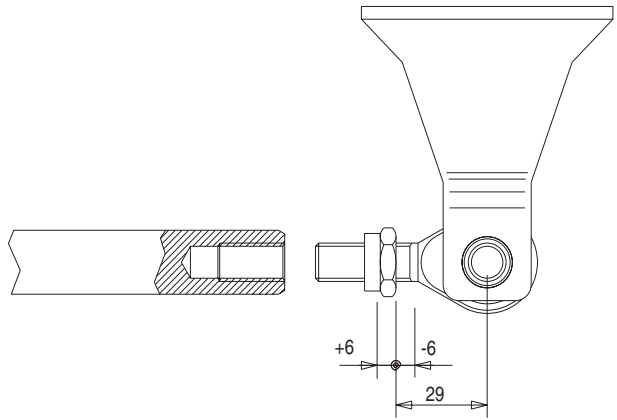

Fig. 10

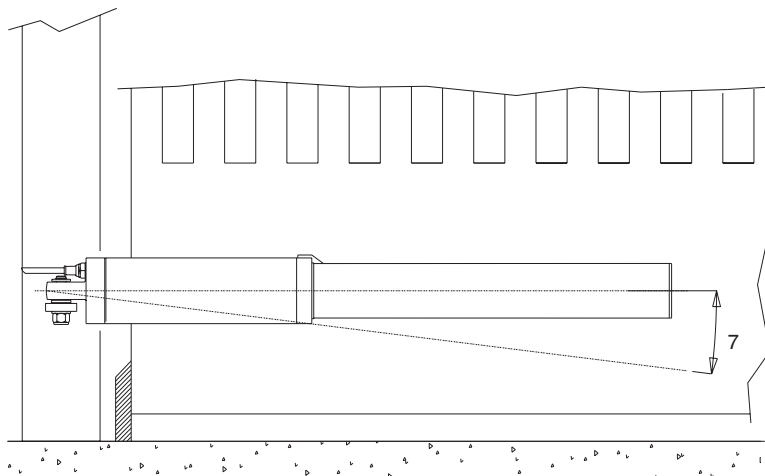

Fig. 11

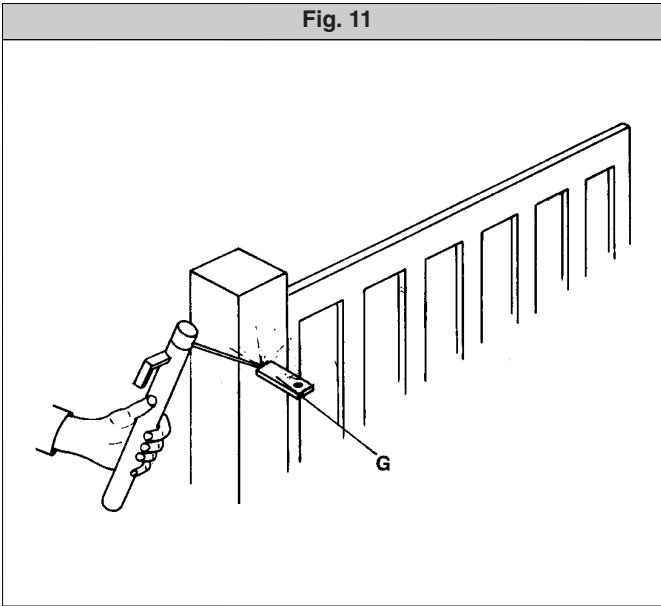

Fig. 12 13 14

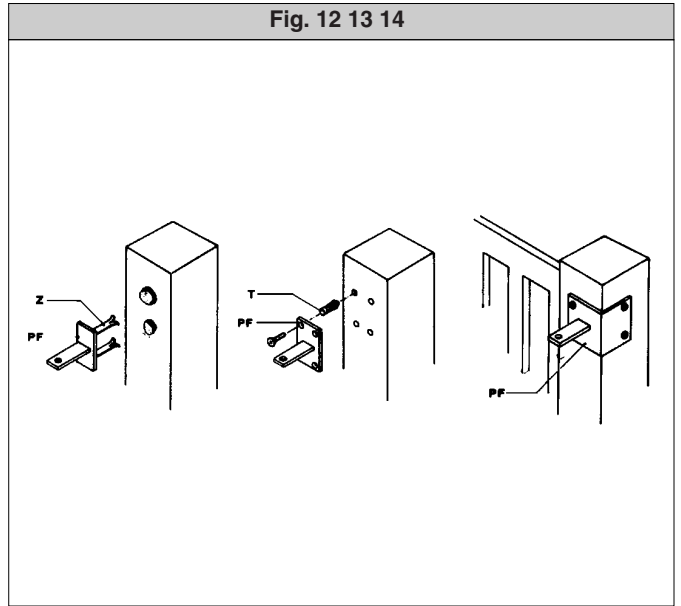

Fig. 15

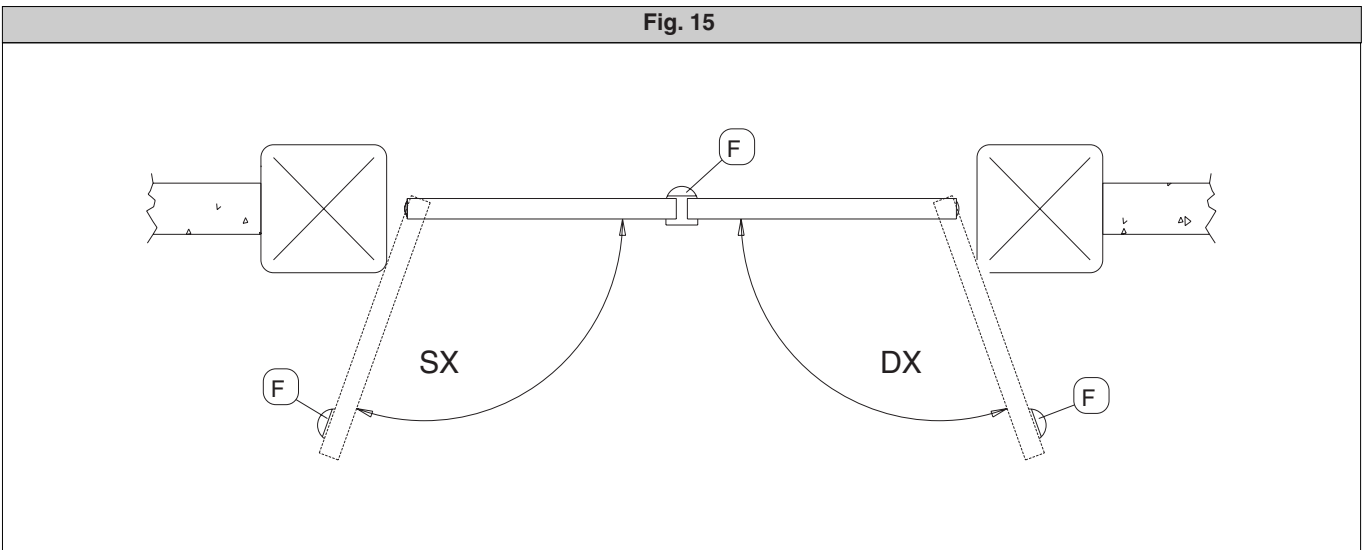

Fig. 16

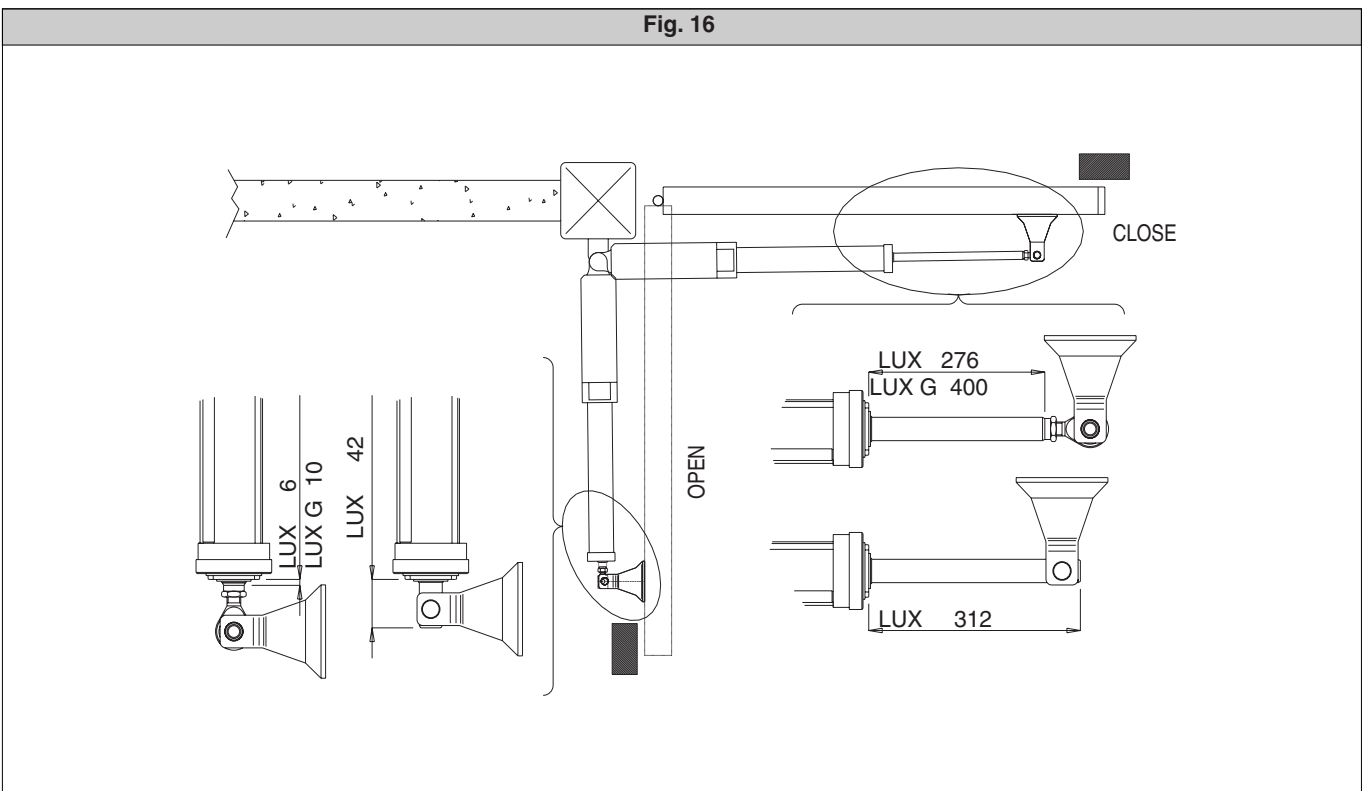

Fig. 17

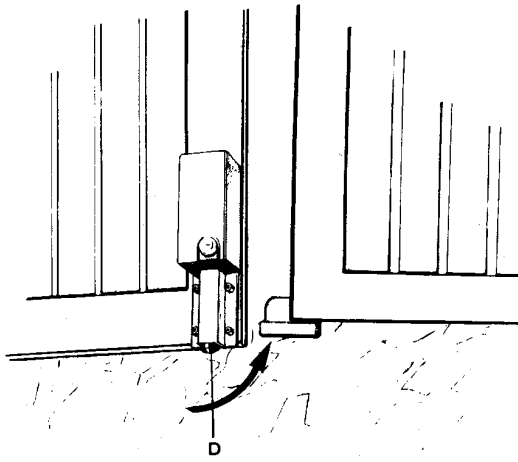

Fig. 18

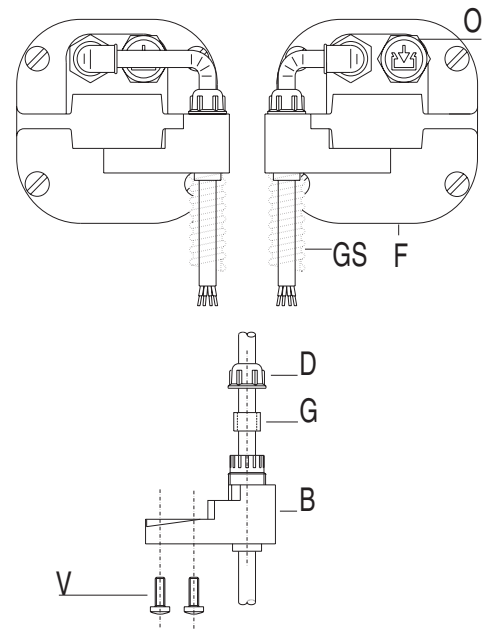

Fig. 19

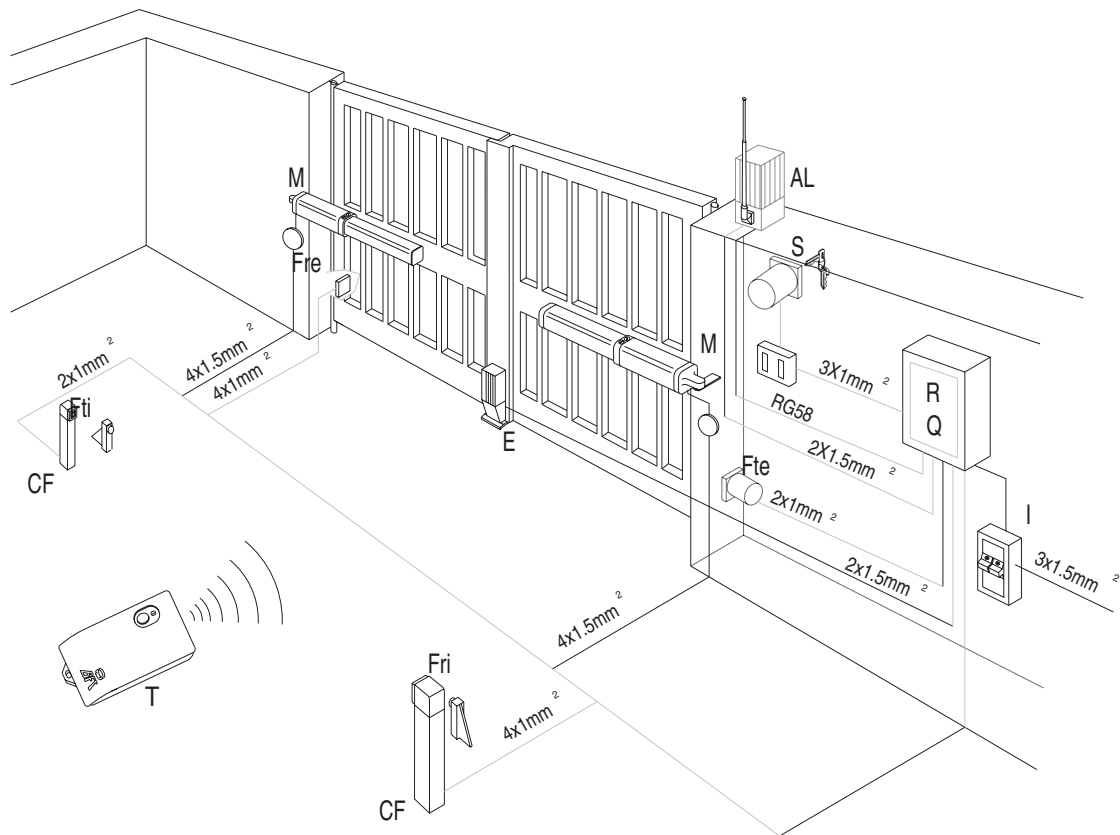

Fig. 20

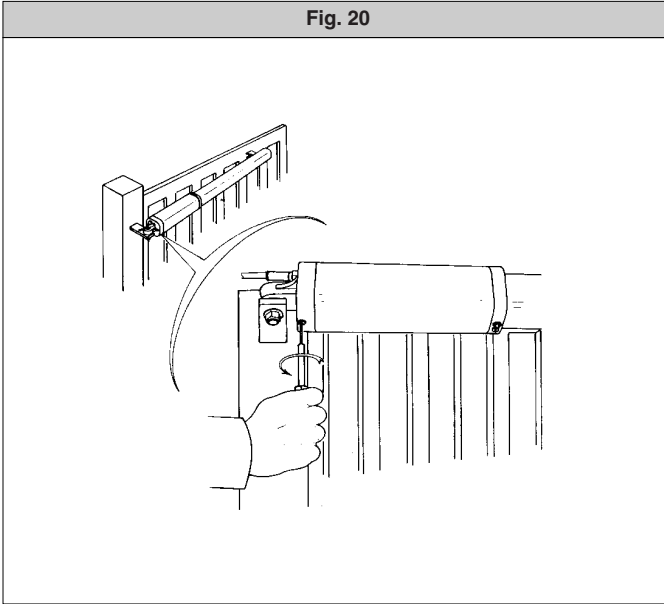

Fig. 21

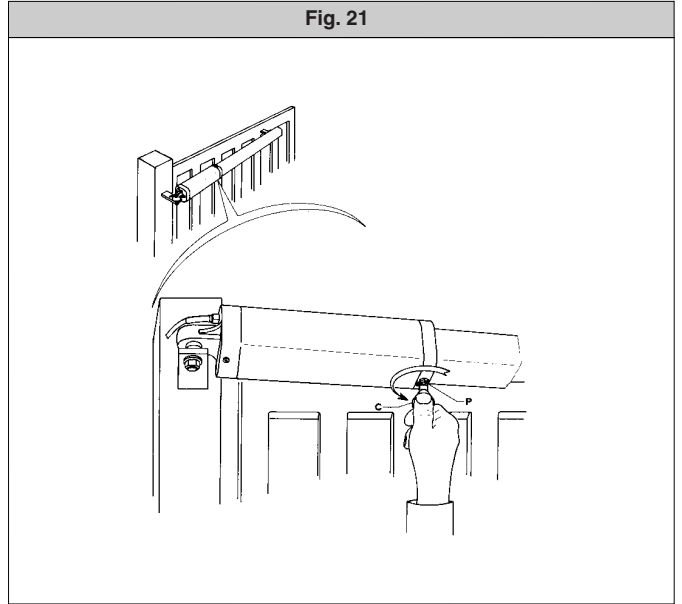

Fig. 22

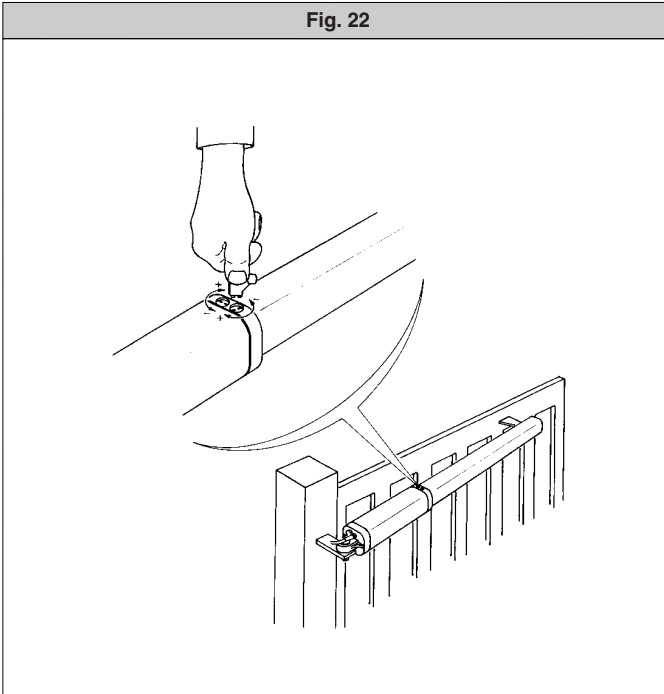

Fig. 23

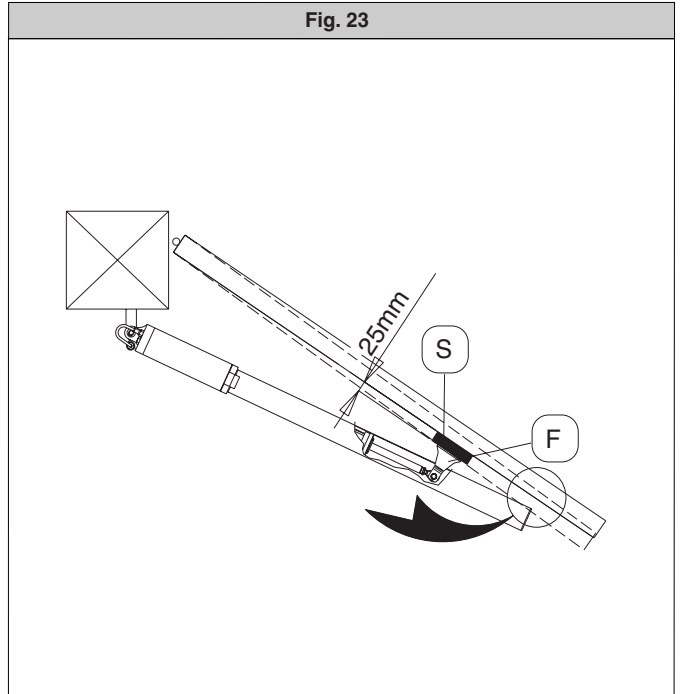

Fig. 24

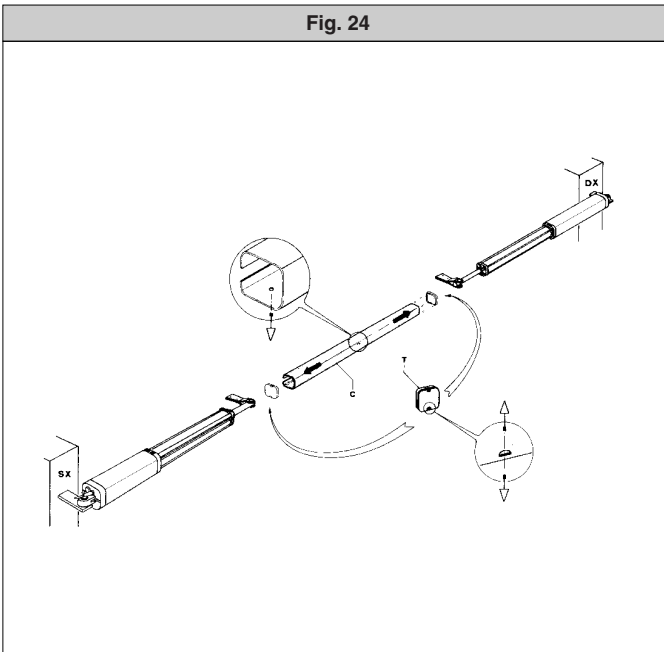

Fig. 25

