

:BA230



BA230 - (AS05550)

Apparecchiatura elettronica
ISTRUZIONI PER L'INSTALLAZIONE

Electronic control unit
INSTRUCTIONS FOR INSTALLATIONS

- I**
- Questo prodotto è stato collaudato in Gi.Bi.Di. verificando la perfetta corrispondenza delle caratteristiche alle direttive vigenti.
 - La Gi.Bi.Di. S.r.l. si riserva la facoltà di modificare i dati tecnici senza avviso, in funzione dell'evoluzione del prodotto.



LEGGERE ATTENTAMENTE QUESTO MANUALE PRIMA DI PROCEDERE ALL'INSTALLAZIONE.

- UK**
- This product has been tested in Gi.Bi.Di. verifying the perfect correspondence of the characteristics to the current directive.
 - Gi.Bi.Di. S.r.l. reserves the right to modify the technical data without prior notice depending on the product development.



PLEASE READ CAREFULLY THIS MANUAL BEFORE PROCEEDING WITH THE INSTALLATION.

- F**
- Ce produit a été essayé en Gi.Bi.Di. en vérifiant la correspondance parfaite des caractéristiques aux règles en vigueur.
 - Gi.Bi.Di. S.r.l. se réserve la faculté de modifier les données techniques sans aucun préavis suivant l'évolution de ses produits.



SI IL VOUS PLAÎT DE LIRE AVEC ATTENTION CETTE MANUAL AVANT DE PROCÉDER AVEC L'INSTALLATION.

- E**
- Este producto ha sido probado en Gi.Bi.Di. averiguando la perfecta correspondencia de las características a las normas vigentes.
 - La empresa Gi.Bi.Di. S.r.l. se reserva el derecho de modificar los datos técnicos sin previo aviso, en función de la evolución del producto.



POR FAVOR LEER CON ATENCIÓN ESTE MANUAL ANTES DE PROCEDER CON LA INSTALACIÓN.

- D**
- Dieses Produkt wurde in Gi.Bi.Di. geprüft um die perfekte Entsprechung der merkmale an die geltende vorschriften zu prüfen.
 - Gi.Bi.Di. S.r.l. behält sich das recht vor, die technischen daten der produktentwicklung entsprechend ohne voranzeige abzuändern.



BITTE LESEN SIE VORSICHTIG DIESEN MANUAL BEVOR MIT DER ANGLAGE VORZUGEHEN.

- P**
- Este produto foi testado em Gi.Bi.Di. verificando a correspondência perfeita das características ao normas vigentes.
 - A Gi.Bi.Di. S.r.l. reserva-se o direito de modificar os dados técnicos sem pré-aviso em função de evolução do produto.



LER COM ATENÇÃO ESTE MANUAL ANTES DE PROCEDER COM A INSTALAÇÃO.

- NL**
- Dit product werd gekeurd in Gi.Bi.Di. Er werd nauwlettend gecontroleerd of de kenmerken van het product perfect overeenkomen met de geldige richtlijnen.
 - Gi.Bi.Di. S.r.l. behoudt zich het recht voor de technische gegevens te wijzigen zonder waarschuwing vooraf, als dat nodig is voor de evolutie van het product.



LEES DEZE GEBRUIKSAANWIJZING ZEER AANDACHTIG ALVORENS DE INSTALLATIE AAN TE VATTEN.

- GR**
- Η εταιρία Gi.Bi.Di. S.r.l. έχει ελέγξει αυτό το προϊόν όσον αφορά την τέλεια προσαρμογή των χαρακτηριστικών του στην ισχύουσα νομοθεσία.
 - Η εταιρία Gi.Bi.Di. S.r.l διατηρεί το δικαίωμα αλλαγής των τεχνικών προδιαγραφών χωρίς προειδοποίηση, όσον αφορά ανάπτυξη των προϊόντων της.



LEES DEZE GEBRUIKSAANWIJZING ZEER AANDACHTIG ALVORENS DE INSTALLATIE AAN TE VATTEN.

1

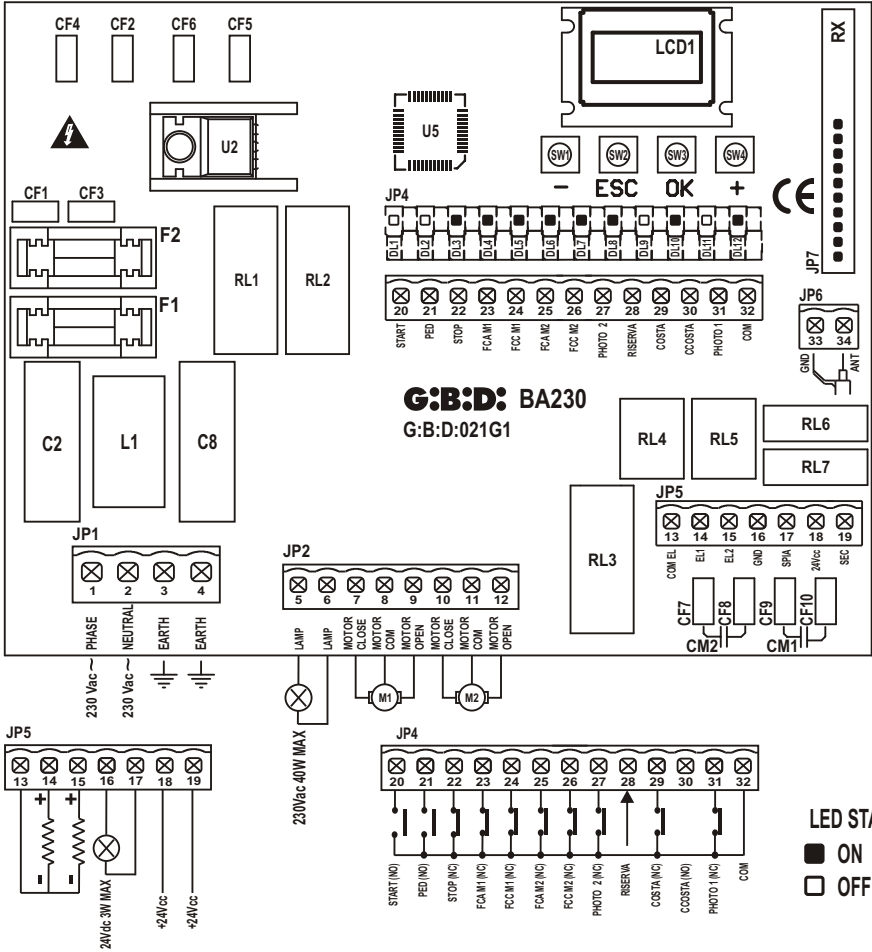

2

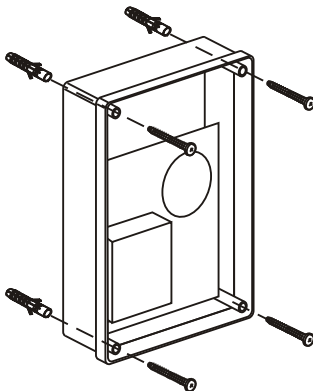

3

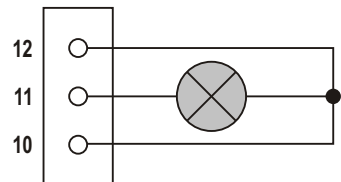

Control unit	BA230 / AS05550
Type	Electronic control unit for the automation of one or two 230V motors for swinging and sliding gates, overhead doors and barriers
Power supply	230Vac monophase 50/60 Hz
N° motors	1 or 2
Motor power supply	230Vac
Flashing light	230Vac 40W max
Warning light	24Vdc 3W max
Electric lock	12Vdc 15W max
Accessory power supply	24Vdc 8W max including safety devices power supply
Safety device power supply	24Vdc 8W max including accessories power supply
Radio receiver	Plug-in
Operating temperature	-20°C +60°C
Operating time	300s max

TECHNICAL SPECIFICATIONS / FUNCTIONS

- Times self-learning.
- Red warning leds of n.c. contacts. There is not the safety devices led (ex. edge), the possible anomaly is indicated by the writing SAF on the LCD.
- Green warning leds of n.o. contacts.
- Two independent 12Vdc electrical locks management.
- Management of courtesy light with 12 Vdc or 230 Vac output.
- Safety test run before the opening and closing movement.
- Photocell 1 test run before the opening and closing movement.
- Stop and motion inversion for 2 s after the intervention of the safety devices. At the next start pulse, the motion restarts in the obstacle freeing direction.
- SEPARATE SAFETY DEVICES POWER SUPPLY. The connection to this power supply will allow the TEST of the devices before the motion. Connect to this clamp the safety devices that will be supplied only during the operating cycle.
- Digital programming of all functions.
- Working time adjustable independently in opening and closing for each single motor.
- Deceleration time adjustable independently in opening and closing for each single motor in the motion final phase (soft-stop).
- Gate phase shift time adjustable independently in opening and closing.
- Adjustable pedestrian working time.
- Adjustable and differentiated pause time for complete or pedestrian opening.
- Adjustable thrust force with 3 modalities on 10 levels for each motor.
- Selectable and independently adjustable decelerations with 3 modalities on 10 levels for each motor.
- Decelerations enabling with single or double limit switch.
- 4 possible working functions (step-by-step, step-by-step with stop, condominium or automatic, dead man).
- Possibility of choosing the system configuration from swing gate, overhead/barrier and sliding gate, single or double.
- SAFETY DEVICE choice with N.C. contact or 8K2 resistive.
- Specific menu for the exclusion of the accessories not used (photocell 1, photocell 2 and safety devices).

UK

- Management of courtesy light with 12 Vdc or 230 Vac output.
- Possibility to program: automatic closing, fast closing, pre-flashing, hammer stroke, final closing and opening stroke, courtesy light, ending movement additional time, flashing light (both flashing and fixed), external clock management with three different modes, number of cycles for scheduled maintenance, installer code and number of performed cycles.

INSTALLATION

Use glands adequate to ensure proper mechanical connection of cable and maintain the box protection degree IP55. (2)

INSTALLATION WARNINGS

- Before proceeding with the installation, fit a magnetothermal or differential switch with a maximum capacity of 10A upstream of the system. The switch must guarantee omnipolar separation of the contacts, with an opening distance of at least 3 mm.
- To prevent possible interference, differentiate and always keep the power cables (minimum cross-section 1,5mm²) separate from the signal cables (minimum cross-section 0,5mm²).
- Make the connections referring to the following tables and to the attached screen-print. Be extremely careful to connect in series all the devices that must be connected to the same N.C. (normally closed) input, and in parallel all the devices that share the same N.O. (normally open) input. Incorrect installation or improper use of the product may compromise system safety.
- Keep all the materials contained in the packaging away from children, since they pose a potential risk.
- The manufacturer declines all responsibility for improper functioning of the automated device if the original components and accessories suitable for the specific automation are not used.
- At the end of the installation, always check carefully the proper functioning of the system and the devices used.
- This instruction manual addresses people qualified for the installation of "live equipment". Therefore, good technical knowledge and professional practice in compliance with the regulations in force are required.
- Maintenance must be carried out by qualified personnel.
- Before carrying out any cleaning or maintenance operation, disconnect the control unit from the mains.
- This control unit may only be used for the purpose for which it was designed.
- Use of the product for purposes different from the intended use has not been tested by the manufacturer, therefore any work is carried out on full responsibility of the installer.
- Mark the automated gate with visible warning plates.
- Warn the user that children and animals may not play or stand around near the gate.
- Appropriately protect the dangerous points (for example, use a sensitive frame).

WARNINGS FOR THE USER

In the event of an operating fault or failure, cut the power upstream of the control unit and call the Technical Service.

Periodically check the functioning of the safety devices. Any repairs must be carried out by specialised personnel using original and certified materials.

The appliance is not to be used by children or people with reduced physical, sensory or mental capabilities, or lack of experience and knowledge, unless they have been given supervision or instruction.

Do not touch the card for adjustments and/or maintenance.

**WARNING: IMPORTANT SAFETY INSTRUCTIONS.**

It is very important to follow the present instructions for your own safety.

Please keep this manual.

ELECTRICAL CONNECTIONS: FASTON

1	CF1 - CF3	Primary connection of 230Vac transformer (black cables)
2	CF2 - CF4	Secondary connection of 14Vac transformer (red cables)
3	CF5 - CF6	Secondary connection of 22Vac transformer (blue cables)
4	CF7 - CF8	Motor 2 capacitor connection
5	CF9 - CF10	Motor 1 capacitor connection

ELECTRICAL CONNECTIONS: TERMINAL BOARDS

Morsetto	Posizione	Segnale	Descrizione
JP1	1	PHASE	Power supply 230Vac
	2	NEUTR	Power supply 230Vac
	3	GND	Ground wire connection
	4	GND	Ground wire connection
JP2	5	LAMP	Flashing light output 230Vac 40W
	6	LAMP	Flashing light output 230 Vac 40W
	7	OPEN	Motor 1 connection 1 (opening)
	8	COM	Common motor 1
	9	CLOSE	Motor 1 connection 1 (closing)
	10	OPEN	Motor 2 connection (opening)
	11	COM	Common motor 2
	12	CLOSE	Motor 2 connection (closing)
JP5	13	COM	Negative electrical lock
	14	EL1	Positive +12 Vdc motor 1 electrical lock
	15	EL2	Positive +12 Vdc motor 2 electrical lock
	16	GND	Negative external accessories power supply
	17	SPIA	Warning light output +24 Vdc 3W max
	18	+ ACC	External accessories (photocells, radio...) +24Vdc power supply
	19	+ SAF	External safety devices +24Vdc power supply. CAUTION: output present only during the operating cycle
	JP4	20	START
21		PED	PEDESTRIAN input (N.O.) (It opens for the time set in menu H10). WARNING After an emergency intervention with motion intervention of the second leaf, the pedestrian command will start both motors.
22		STOP	STOP input (N.C.). If not used, jump with terminal n° 32
23		FCAM1	Limit switch input opens motor 1 (N.C.). If not used, disable during the programming phase.
24		FCCM1	Limit switch input closes motor 1 (N.C.). If not used, disable during the programming phase.

Operation:
Fast flashing during opening, off during pause, slow flashing during closing

Operation:
Slow flashing during opening, fixed light during pause, fast flashing during closing.

UK

JP4	25	FCAM2	Limit switch input opens motor 2 (N.C.). If not used, disable during the programming phase.
	26	FCCM2	Limit switch input closes motor 2 (N.C.). If not used, disable during the programming phase.
	27	PH2	PHOTOCELL 2 input (N.C.). If not used, disable during the programming phase. Operation: Input enabled during both opening and closing. If intercepted, it stops the motion immediately and holds it stopped until the photocell is freed. Upon release, motion always starts in opening. If intercepted when the gate is closed, following a Start command it does not allow the opening of the gate: this will be signalled with 5 fast flashes, then the warning light turns on to indicate that the door is not in stand-by. Upon release, the gate will start opening without further commands. If intercepted during pause, it reloads the pause time.
	28	RISERVA	Multitasking input External watch: SEE PROGRAMMING C16-C17-C18
	29	COSTA	SAFETY DEVICES input (see menu C9) If not used, disable during the programming phase. Operation: Input enabled during both opening and closing. It stops and inverts the motion for 2 s. The gate will remain locked until the next Start pulse, which will make it start in the obstacle-freeing direction. If the input is enabled when the door is in stand-by, after a Start or a Pedestrian command the door will not move and 3 long flashes (2 sec.) will signal the fault. If the input is enabled when the door is in pause, the door does not close automatically (if automatic closing is enabled) and 3 long flashes (2 sec.) will signal the fault. THE EDGE ENABLING IS SIGNALLED BY THE WRITING "SAF" ON THE LCD.
	30		Not used
	31	PH1	PHOTOCELL 1 input (N.C.). If not used, disable during the programming phase. Operation: Input enabled only during closing. It stops and inverts the motion, opening the gate completely. If the gate is closed, it does not affect its functioning. If intercepted during pause, it reloads pause time (if C2 disabled). It can be enabled to manage FAST CLOSING.
	32	COM	COMMON INPUTS - OUTPUTS
JP6	33	GND	ANTENNA BRAID input
	34	ANT	ANTENNA SIGNAL input
JP7			Connector for plug-in radio receiver

PROTECTION FUSES

Position	Value	Type	Description
F1	6 A	FAST	Motors and primary transformer protection
F2	315 mA	FAST	Low tension and accessories protection

PROGRAMMING PROCEDURE AND SYSTEM CONFIGURATION

The system adjustments can be accessed via the display. There are 5 different menus marked with the letters A, C, F, H and E.

<div style="border: 1px solid black; padding: 10px; text-align: center;"> - - - Gbd - - - </div> <div style="display: flex; justify-content: center; gap: 10px; margin-top: 10px;"> - ESC OK + </div>	<p style="text-align: center;">1</p> <p>To enter the programming procedure, start from the display as shown in the picture and press simultaneously the keys ESC and OK for 3 s (The writing Gbd will turn off)</p> <p>Go to step 2.</p>
<div style="border: 1px solid black; padding: 10px; text-align: center;"> - - - PASS - - - </div> <div style="display: flex; justify-content: center; gap: 10px; margin-top: 10px;"> - ESC OK + </div>	<p style="text-align: center;">2</p> <p>The writing PASS appears on the display. Press the OK key to go to step 3. Pressing simultaneously the keys + and - for 3 s, all default settings will be loaded (only the performed cycles settings remain stored). Press the ESC key to go back to step 1.</p>
<div style="border: 1px solid black; padding: 10px; text-align: center;"> 0 0 0 0 </div> <div style="display: flex; justify-content: center; gap: 10px; margin-top: 10px;"> - ESC OK + </div>	<p style="text-align: center;">3</p> <p>4 figures appear on the display (0000), the first one is flashing.</p> <p>With the + or – keys, the user selects the first digit of the installer code.</p> <p>When the required digit is selected, press OK to confirm and go to step 4.</p>
<div style="border: 1px solid black; padding: 10px; text-align: center;"> 4 0 0 0 </div> <div style="display: flex; justify-content: center; gap: 10px; margin-top: 10px;"> - ESC OK + </div>	<p style="text-align: center;">4</p> <p>The second figure is flashing. With the + or – keys, the user selects the second digit of the installer code.</p> <p>When the required digit is selected, press OK to confirm and go to step 5.</p>
<div style="border: 1px solid black; padding: 10px; text-align: center;"> 4 6 0 0 </div> <div style="display: flex; justify-content: center; gap: 10px; margin-top: 10px;"> - ESC OK + </div>	<p style="text-align: center;">5</p> <p>The third digit is flashing. With the + or – keys, the user selects the third digit of the installer code.</p> <p>When the required digit is selected, press OK to confirm and go to step 6.</p>

UK

<div style="border: 1px solid black; width: 200px; height: 40px; margin: 0 auto; text-align: center; line-height: 40px;">4 6 8 0</div> <div style="display: flex; justify-content: center; gap: 10px; margin-top: 10px;"> <div style="border: 1px solid black; padding: 2px 10px;">-</div> <div style="border: 1px solid black; padding: 2px 10px;">ESC</div> <div style="border: 1px solid black; padding: 2px 10px;">OK</div> <div style="border: 1px solid black; padding: 2px 10px;">+</div> </div>	<p style="text-align: center;">6</p> <p>The last figure is flashing. With the + or – keys, the user selects the fourth digit of the installer code.</p> <p>When the required digit is selected, press OK to confirm and go to step.</p>
<div style="border: 1px solid black; width: 200px; height: 40px; margin: 0 auto; text-align: center; line-height: 40px;">4 6 8 3</div> <div style="display: flex; justify-content: center; gap: 10px; margin-top: 10px;"> <div style="border: 1px solid black; padding: 2px 10px;">-</div> <div style="border: 1px solid black; padding: 2px 10px;">ESC</div> <div style="border: 1px solid black; padding: 2px 10px;">OK</div> <div style="border: 1px solid black; padding: 2px 10px;">+</div> </div>	<p style="text-align: center;">7</p> <p>Now the installer code is complete: if it is correct, go to step 8. If the installer code is incorrect, go back to step 2.</p>

PROGRAMMING EXAMPLE

<p>MENU A</p> <div style="border: 1px solid black; width: 200px; height: 40px; margin: 0 auto; text-align: center; line-height: 40px;">A C F H E</div> <div style="display: flex; justify-content: center; gap: 10px; margin-top: 10px;"> <div style="border: 1px solid black; padding: 2px 10px;">-</div> <div style="border: 1px solid black; padding: 2px 10px;">ESC</div> <div style="border: 1px solid black; padding: 2px 10px;">OK</div> <div style="border: 1px solid black; padding: 2px 10px;">+</div> </div>	<p style="text-align: center;">8</p> <p>The 5 main menus appear on the display (letters A C F H E), the A is flashing.</p> <p>Use the + or – keys to select the other menus (the relative letter will blink).</p> <p>Press OK to enter the selected menu (in the example, menu A).</p>
<div style="border: 1px solid black; width: 200px; height: 40px; margin: 0 auto; text-align: center; line-height: 40px;">A 5 Y</div> <div style="display: flex; justify-content: center; gap: 10px; margin-top: 10px;"> <div style="border: 1px solid black; padding: 2px 10px;">-</div> <div style="border: 1px solid black; padding: 2px 10px;">ESC</div> <div style="border: 1px solid black; padding: 2px 10px;">OK</div> <div style="border: 1px solid black; padding: 2px 10px;">+</div> </div>	<p style="text-align: center;">9</p> <p>Use the + or – keys to enter the submenus (A1, A2, A3, A4, ...)</p> <p>Press OK to confirm the selected menu; a "Y" will appear next to the menu to indicate that it is enabled.</p>
<div style="border: 1px solid black; width: 200px; height: 40px; margin: 0 auto; text-align: center; line-height: 40px;">A 5</div> <div style="display: flex; justify-content: center; gap: 10px; margin-top: 10px;"> <div style="border: 1px solid black; padding: 2px 10px;">-</div> <div style="border: 1px solid black; padding: 2px 10px;">ESC</div> <div style="border: 1px solid black; padding: 2px 10px;">OK</div> <div style="border: 1px solid black; padding: 2px 10px;">+</div> </div>	<p style="text-align: center;">10</p> <p>With the + and – keys the other submenus are displayed; follow the same procedure as above.</p> <p>Press ESC to go back to the higher level (menu A, C, F, H, E).</p>

MENU C	11
<div style="border: 1px solid black; padding: 10px; text-align: center; margin-bottom: 10px;">A C F H E</div> <div style="display: flex; justify-content: center; gap: 10px;"> - ESC OK + </div>	<p>When the 5 main menus are shown on the display (letters A C F H E) and the letter C is blinking.</p> <p>Press OK to enter the selected menu (in the example, menu C).</p>
<div style="border: 1px solid black; padding: 10px; text-align: center; margin-bottom: 10px;">C 1 Y</div> <div style="display: flex; justify-content: center; gap: 10px;"> - ESC OK + </div>	<p>12</p> <p>Use the + or – keys to select the various submenus.</p> <p>Press OK in sequence to:</p> <p>Enable the input (the Y will appear next to C1)</p> <p>Disable the input (the N will appear next to C1)</p>
MENU H	13
<div style="border: 1px solid black; padding: 10px; text-align: center; margin-bottom: 10px;">A C F H E</div> <div style="display: flex; justify-content: center; gap: 10px;"> - ESC OK + </div>	<p>Enter the H1 submenu to see the setting of a numeric value.</p> <p>Use the + and – to select the menu H; it will blink.</p> <p>Press OK to enter the menu.</p>
<div style="border: 1px solid black; padding: 10px; text-align: center; margin-bottom: 10px;">H 1</div> <div style="display: flex; justify-content: center; gap: 10px;"> - ESC OK + </div>	<p>14</p> <p>Use the + or – keys to select the submenus.</p> <p>Press key to enter the selected submenu.</p>
<div style="border: 1px solid black; padding: 10px; text-align: center; margin-bottom: 10px;">0 1 0 0</div> <div style="display: flex; justify-content: center; gap: 10px;"> - ESC OK + </div>	<p>15</p> <p>The stored value appears, with the first digit blinking.</p> <p>Use the + and – keys to modify the value of this digit.</p> <p>Press OK to confirm and go to step 16.</p>
<div style="border: 1px solid black; padding: 10px; text-align: center; margin-bottom: 10px;">0 1 0 0</div> <div style="display: flex; justify-content: center; gap: 10px;"> - ESC OK + </div>	<p>16</p> <p>The second digit blinks.</p> <p>Use the + and – keys to modify the value of this digit.</p> <p>Press OK to confirm and go to step 17.</p>

UK

<div style="border: 1px solid black; width: 200px; height: 40px; margin: 0 auto; text-align: center; line-height: 40px;">0 1 0 0</div> <div style="display: flex; justify-content: center; gap: 10px; margin-top: 10px;"> - ESC OK + </div>	<p>17</p> <p>The third digit blinks. Use the + and – keys to modify the value of this digit. Press OK to confirm and go to step 18.</p>
<div style="border: 1px solid black; width: 200px; height: 40px; margin: 0 auto; text-align: center; line-height: 40px;">0 1 5 0</div> <div style="display: flex; justify-content: center; gap: 10px; margin-top: 10px;"> - ESC OK + </div>	<p>18</p> <p>The fourth digit blinks. Use the + and – keys to modify the value of this digit. Press OK to confirm and go to step 19.</p>
<div style="border: 1px solid black; width: 200px; height: 40px; margin: 0 auto; text-align: center; line-height: 40px;">H 1</div> <div style="display: flex; justify-content: center; gap: 10px; margin-top: 10px;"> - ESC OK + </div>	<p>19</p> <p>The H1 menu indication reappears. Now press ESC to go back to the higher level.</p>
<p>MENU E</p> <div style="border: 1px solid black; width: 200px; height: 40px; margin: 0 auto; text-align: center; line-height: 40px;">A C F H E</div> <div style="display: flex; justify-content: center; gap: 10px; margin-top: 10px;"> - ESC OK + </div>	<p>20</p> <p>Enter the submenu E to see the ENABLING/DISABLING setting. Press OK to enter the menu.</p>
<div style="border: 1px solid black; width: 200px; height: 40px; margin: 0 auto; text-align: center; line-height: 40px;">E 1 Y</div> <div style="display: flex; justify-content: center; gap: 10px; margin-top: 10px;"> - ESC OK + </div>	<p>21</p> <p>E1 = PHOTOCCELL 1</p> <p>Press OK in sequence to: Enable input (the Y will appear next to E1) Disable the input (The N will appear next to E1)</p> <p>Use the + and – keys to enter the following or the previous menu. Press ESC to leave the menu; “ACFHE” is now shown on the display.</p>
<div style="border: 1px solid black; width: 200px; height: 40px; margin: 0 auto; text-align: center; line-height: 40px;">E 2 Y</div> <div style="display: flex; justify-content: center; gap: 10px; margin-top: 10px;"> - ESC OK + </div>	<p>22</p> <p>E2 = PHOTOCCELL 2</p> <p>Press OK in sequence to: Enable the input (the Y will appear next to E2) Disable the input (the N will appear next to E2)</p> <p>Use the + and – keys to enter the following or the previous submenu. Press ESC to leave the menu; “ACFHE” is now shown on the display.</p>

<div style="border: 1px solid black; padding: 5px; text-align: center; margin-bottom: 5px;">E 3 Y</div> <div style="display: flex; justify-content: center; gap: 10px;"> - ESC OK + </div>	<p>23</p> <p>E3 = SAFETY DEVICE (EDGE)</p> <p>Press OK in sequence to: Enable the input (the Y will appear next to E3) Disable the input (the N will appear next to E3)</p> <p>Use the + and – keys to enter the following or the previous menu. Press ESC to leave the menu; "ACFHE" is now shown on the display.</p>
<div style="border: 1px solid black; padding: 5px; text-align: center; margin-bottom: 5px;">A C F H E</div> <div style="display: flex; justify-content: center; gap: 10px;"> - ESC OK + </div>	<p>24</p> <p>Press ESC to store the settings and leave the programming phase, accessing normal operation.</p>
<div style="border: 1px solid black; padding: 5px; text-align: center; margin-bottom: 5px;"> Gbd </div> <div style="display: flex; justify-content: center; gap: 10px;"> - ESC OK + </div>	<p>25</p> <p>The starting symbols reappear on the LCD. At this point, the +, - and OK keys mean:</p> <p>+ → START - → PEDONALE OK → STOP</p>

MENU A: SYSTEM CONFIGURATION AND OPERATING LOGIC SELECTION

KEY + enters the following menu A1-A2-A3-...

KEY – enters the previous menu A3-A2-A1-...

KEY ESC leaves the menu

KEY OK enables Y (yes). It enables the function and automatically disables the complementary function (example; the activation of A4 = 1 motor automatically disables A5 = 2 motors)

Menu	Function	Status	Description
A2	SWING / OVERHEAD DOOR / BARRIER	Y	It configures the system for swing gate, overhead door or barrier. The activation of this menu automatically disables A3.
A3	SLIDING GATE	Y	It configures the system for a sliding gate. This configuration automatically excludes: gate phase shifts in opening and closing hammer stroke 2 s opening and closing final stroke T3 additional time NOTE: the limit switches are NOT activated automatically, choose the required configuration with menu C5 The activation of this menu automatically disables A2.
A4	1 MOTOR CONFIGURATION	Y	It configures the system for 1 motor. In the menu C11 it will be possible to set the courtesy light output: N = courtesy light disabled Y1 = courtesy light on MOTOR 2 output (diagram output 230 Vac) (3) Y2 = courtesy light on ELECTRIC LOCK 2 output (see diagram 12 Vdc output) The courtesy light output is 3-minutes timed. The activation of this menu automatically disables A5.

UK

A5	2 MOTORS CONFIGURATION	Y	<p>It configures the system for 2 motors. In the menu C11 it will be possible to set the courtesy light output: surrendering the electric lock 2 N = courtesy light disabled Y1 = courtesy light disabled Y2 = courtesy light on ELECTRIC LOCK 2 output (see diagram 12 Vdc output) The courtesy light output is 3-minutes timed. The activation of this menu automatically disables A4.</p>
A6	STEP BY STEP WITH STOP LOGIC	Y	<p>It enables the STEP BY STEP WITH STOP Logic Operation: Start → open Next Start → stop Next Start → close Next Start → open</p> <p>If automatic closing has been activated (menu C1) and the opening phase is at the end of the cycle, when the pause time has elapsed (menu H9), the control unit automatically closes the gate. During pause, a Start command closes the gate. Pedestrian command is uninfluent in opening and in pause. In closing it opens both leaves. The activation of this menu automatically disables A7-A8-A9.</p>
A7	STEP BY STEP LOGIC	Y	<p>It enables the STEP BY STEP Logic Operation: Start → open Next Start → close Next Start → open</p> <p>If automatic closing has been activated (menu C1) and the opening phase is at the end of the cycle, when the pause time has elapsed (menu H9), the control unit automatically closes the gate. During the pause, a Start command closes the gate. Pedestrian command is uninfluent in opening and in pause. In closing it opens both leaves. The activation of this menu automatically disables A6-A8-A9.</p>
A8	AUTOMATIC / CONDOMINIUM LOGIC	Y	<p>It enables the AUTOMATIC/CONDOMINIUM Logic Operation: Start → apre Next Start(s) → uninfluent if the system is opening or it reloads the pause time (if the gate is in pause) and the automatic closing is enabled.</p> <p>When the pause time has elapsed, if the automatic closing is enabled (menu C1), the system closes automatically. If the automatic closing is disabled, Start closes the gate. If the opening is pedestrian, a pedestrian command closes the gate. Pedestrian is uninfluent in opening and in pause In closing it opens both leaves. The activation of this menu automatically disables A6-A7-A9.</p>
A9	DEAD MAN LOGIC	Y	<p>It enables the DEAD MAN Logic WARNING: 2 motors always operate Operation: Start → closes only if the Pedestrian key is held down. Pedestrian → opens only if the Start key is held down. In Dead Man's mode the keys on the control unit mean: Start (Key +) → open Pedonale (Key -) → close</p>

A9	DEAD MAN LOGIC	Y	The opening and closing movement in the dead man's mode stops always on the first limit switch. The possible regulations are: PHASE SHIFT IN OPENING - PHASE SHIFT IN CLOSING. The enabling of this menu automatically disables A6-A7-A8.
----	----------------	---	---

MENU C: FUNCTIONS SELECTIONS

KEY + enters the following menu C1-C2-C3-...

KEY - enters the previous menu C3-C2-C1...

KEY ESC leaves the menu

KEY OK enables Y (yes). It enables or selects the function

KEY OK enables N (no). It disables the function

Menu	Function	Status	Description
C1	AUTOMATIC CLOSING	YT	Enables automatic closing after both complete opening and pedestrian opening.
		YS	Enables only automatic closing after a complete opening. If pedestrian opening is enabled, the pedestrian key will close the gate.
		YP	Enables only automatic closing after a pedestrian opening.
		N	Disables automatic closing If the pedestrian opening is enabled, the pedestrian key will close the gate. If complete opening is enabled, a Start command will close the gate and the pedestrian key will be unimportant.
C2	FAST CLOSING	Y	Enables fast closing function Operation: Enabled only on photocell 1. Reduces pause time to 3 s following interception and subsequent freeing of the photocells.
		N	Disables fast closing function
C3	PRE-FLASHING	Y	Enables 3-second pre-flashing before motors start
		N	Disables pre-flashing. The flashing light and the motors start at the same time.
C4	SAFETY DEVICES TEST See also menu C20	Y	Enables the safety devices test When the device is enabled (edge intercepted), the writing SAF appears on the LCD Operation: PHASE 1: when the Start or the Pedestrian command is given, the electronic circuit is tested: relay, triac, etc. If an anomaly is detected, it will be indicated by 4 long flashes (2 sec.) of the flashing light. The test must be performed when the motors are connected. If the control unit is set for one motor, the test will be performed only for motor 1 circuit. WARNING: During the test, the motors will be activated in opening and closing for about 300 msec. DUE TO THE MOTION, THE DOOR MAY CRASH AGAINST THE MECHANICAL STOPS. CHECK THE SYSTEM SAFETY/INTEGRITY AFTER THIS PHASE.

UK

C4	SAFETY DEVICES TEST See also menu C20	Y	<p>The exclusion of SAFETY DEVICE by mean of the menu E3 excludes the safety edge test.</p> <p>PHASE 2: if the edge with N.C. contact is enabled, when the Start or Pedestrian command is given, the power to the safety devices is cut off for 0,5 s and then restored: : if the inputs of the safety devices open and immediately return NC, the motors start, otherwise a fault is signalled with 3 long flashes (2 sec.) of the flashing light.</p> <p>PHASE 3: if the 8K2 edge is enabled, when the Start or the Pedestrian command is given the SAFETY DEV input is tested (value 8K2). If the value is not correct, the fault is signalled with 2 long flashes (2 sec.) of the flashing light.</p> <p>The indication of the fault detected will be only one (the first one to be detected), even if there is more than one fault.</p>
		N	Disables the safety devices test.
C5	LIMIT SWITCHES	E1	Enables the single limit switch reading. See the paragraph "USE OF THE LIMIT SWITCHES"
		E2	Enables the double limit switch reading. See the paragraph "USE OF THE LIMIT SWITCHES"
		N	Disables the limit switch reading.
C6	DECELERATIONS	Y1	Enables the type 1 deceleration function.
		Y2	Enables the type 2 deceleration function.
		Y3	Enables the type 3 deceleration function.
		N	Disables the deceleration function.
C7	WATER HAMMER	Y1	<p>Enables the water hammer function to help the release of the electric lock/s in OPENING</p> <p>Operation: After the Start command, the sequence is:</p> <ul style="list-style-type: none"> - Electrical locks enabling - 1 s pulse in closing - opening - After 2 s, electrical locks release <p>Disabled with sliding configuration</p>
		Y2	<p>Enables the water hammer function to help the electrical lock/s release in OPENING and CLOSING</p> <p>Operation: After the Start command, the sequence is:</p> <ul style="list-style-type: none"> - Electrical locks enabling - Motor pulse in the electrical lock freeing direction - Motion direction in the required direction - After 2 s, electrical locks release <p>Disabled with sliding configuration</p>
		N	Disables the water hammer function.
C8	FINAL STROKE IN OPENING AND CLOSING	Y	<p>Enables the final stroke in opening and closing</p> <p>Operation: At the end of the opening and closing time without decelerations, a 2 s pulse with full power is given.</p>

C8	FINAL STROKE IN OPENING AND CLOSING	Y	If decelerations are enabled, the pulse is given at the end of the deceleration time. The final stroke is not managed by the safety devices. Disabled with sliding configuration and with dead man logic
		N	Disables the closing final stroke function.
C9	SAFETY DEVICE	8K2	Enables the edge with 8K2 in series resistance. Runs the safety test on the 8K2 edge (check the correct resistive value) if enabled with menu C4 – E3.
		NC	Enables the edge provided with n.c. contact (normally closed). Runs the safety test on the n.c. edge if enabled with menu C4 - E3.
C10	DISABLED		
C11	COURTESY LIGHT	Y1	Enables the courtesy light working on motor 2 output . If the installation has 2 motors the courtesy light will not be active COURTESY LIGHT 230 Vac (see diagram). Timed 3 min after the motors motion end.
		Y2	Enables the courtesy light working on electrical lock 2 output COURTESY LIGHT 12 Vdc. Timed 3 min after the motors motion end.
		N	Disables the courtesy light.
C13	T3 ADDITIONAL TIME	N	T3 excluded.
		YF	Sets T3 as the time set for the deceleration with the same setting of menus F1 and F5.
		YS	Sets T3 as the time set for the deceleration with the same setting of menus F2 and F6.
C14	INVERSION FROM PEDESTRIAN	Y	During the PEDESTRIAN closing, the PHOTO1-PHOTO2-PEDESTRIAN command will determine only the pedestrian opening. The START will cause complete opening.
		N	During the PEDESTRIAN closing, the PHOTO1-PHOTO2-PEDESTRIAN-START command will cause the complete opening.
C15	FLASHING LIGHT	Y	Blinking flashing light output (slow blinking in opening, fast in closing).
		N	Flashing light fixed output.
C16	EXTERNAL WATCH, CLOSING ALLOWED	Y	Enables the RESERVE input for the connection of an external watch. Operation: If the contact on the RESERVE input is closed, following a START command the door opens but does not close automatically. When the contact closes, after the pause time the door will close automatically. When the door is open, closing can be started with a START command if the menu enabled is STEP-BY-STEP or STEP-BY-STEP WITH STOP. CAUTION: remember to set automatic closing.
		N	Disables the RESERVE input.

UK

C17	EXTERNAL WATCH, CLOSING NOT ALLOWED	Y	Enables the RESERVE input for the connection of an external watch Operation: If the contact on the RESERVE input is closed, following a START command the door opens but does not close automatically. When the contact closes, after the pause time the door will close automatically. Closing cannot be started with a START command. CAUTION: remember to set automatic closing.
		N	Disables the RESERVE input.
C18	EXTERNAL WATCH AUTOMATIC OPENING AND CLOSING COMMAND	Y	Enables the RESERVE input for the connection of an external watch Operation: When the contact on the RESERVE input is closed, an automatic opening command will be enabled (a START command is not required). The door will open but will not close automatically. When the contact is closed, the door will close automatically after the pause time. Closing cannot be enabled with START. CAUTION: remember to set automatic closing.
		N	Disabilita l'ingresso RISERVA.
C19	OLEODYNAMIC BLOCK MAINTENANCE	Y	Enables the oleodynamic block maintenance function ONLY FOR OLEODYNAMIC OPERATORS Operation: If in the last 5 hours the gate has not performed a manoeuvre, a 2 s pulse in closing is given. The enabling of the STOP key in any moment disables the function. The function is automatically disabled with SLIDING - DEAD MAN configuration
		N	Disables the oleodynamic block maintenance
C20	PHOTOCELL 1 TEST	Y	Enables photocell 1 test. The photocell 1 transmitter must be connected to the clamps 16 and 19. Operation: When the "Start" or the "Pedestrian" command is given, the power to safety devices is cut off for 0,5 and then restored: if the photocell 1 input opens and immediately returns NC the motors start, otherwise a fault will be signalled by 4 blinks (1 sec.) of the flashing light.
		N	Disables photocell 1 test 1.
C21	AUTOMATIC PROGRAMMING	Y	Enables times programming in self-learning. Operation: See "Times self-learning procedure".

MENU F: FORCE AND SPEED ADJUSTMENTS

Menu	Function	Description
F1	MOTOR 1 FORCE	Adjusts motor 1 thrust. 0001 = minimum force. 0010 = maximum force.

F2	MOTOR 1 DECELERATION SPEED 1	Adjusts motor 1 thrust during deceleration phase. 0001 = minimum force. 0010 =maximum force.
F5	MOTOR 2 FORCE	Adjusts motor 2 thrust. 0001 = minimum force. 0010 =maximum force.
F6	MOTOR 2 DECELERATION SPEED 2	Adjusts motor 2 thrust during deceleration phase. 0001 = minimum force. 0010 =maximum force.

MENU H: TIMES ADJUSTMENTS AND SETTINGS

All times can be set in steps of 1 s.

Menu	Function	Description
H1	MOTOR 1 OPENING TIME	Leaf 1 opening time. (*) Tmax 300 s.
H2	MOTOR 1 CLOSING TIME	Leaf 1 closing time. (*) Tmax 300 s.
H3	MOTOR 1 DECELERATION TIME	Leaf 1 operating time in deceleration mode. (*) Tmax 100 s.
H4	MOTOR 2 OPENING TIME	Leaf 2 opening time. (*) Tmax 300 s.
H5	MOTOR 2 CLOSING TIME	Leaf 2 closing time. (*) Tmax 300 s.
H6	MOTOR 2 DECELERATION TIME	Leaf 2 operating time in deceleration mode. (*) Tmax 100 s.
H7	LEAF 2 PHASE SHIFT TIME IN OPENING	Delays the start in opening of leaf 2 with respect to leaf 1. In the case of double sliding gate, the time H7 will not be considered. Tmax 100 s.
H8	LEAF 1 PHASE SHIFT TIME IN CLOSING	Delays the start in closing of leaf 1 with respect to leaf 2. In the case of double sliding gate, the time H8 will not be considered. Tmax 100 s.
H9	AUTOMATIC CLOSING PAUSE TIME	Determines the pause time in opening before the automatic closing. Tmax 300 s.
H10	PEDESTRIAN OPENING TIME	Determines the pedestrian opening time. Tmax 300 s.
H11	AUTOMATIC PEDESTRIAN CLOSING PAUSE TIME	Determines the pause time in pedestrian opening before automatic closing. Tmax 300 s.
H12	CYCLES NUMBER	Allows the setting of a number of cycles (opening + closing) before the maintenance request. The value set will always be multiplied for 10. If 0000 is set, the numbering is excluded. When the set number of cycles is reached, the maintenance request is signalled by a slow blink of 60 sec. at the end of the movement. WARNING: Every time you enter the menu H12, the cycles numbering is reset and starts again.
H13	INSTALLER CODE	Allows the input of the installer code to customize the settings in the programming phase. The INSTALLER CODE is the only way to enter the programming menu. WARNING: in case of loss of the installer code, it will be possible to delete the old one by pressing simultaneously the keys + and - for 3 s when the writing PASS appears. In this way, all the existing settings are erased and the default ones are automatically set. Only the settings of the performed cycles are still stored in memory.
H14	SOFTWARE VERSION	Shows the firmware version installed on the equipment. (R_XX)
H15	NUMBER OF PERFORMED CYCLES	Number of performed cycles. The value displayed on the LCD is increased every 10 movements.

(*) time must be sufficient to reach the limit switches

UK

MENU E: EXTERNAL DEVICES ENABLING-DISABLING

KEY + enters the following menu E1-E2-E3
 KEY – enters the previous menu E3-E2-E1
 KEY OK enables Y (yes). Enables the function.
 KEY OK enables N (no). Disables the function.
 KEY ESC leaves the menu.

WARNING: The STOP key cannot be excluded in menu E. If it is not used, jumper the clamps 22-32.

Menu	Function	Status	Description
E1	PHOTOCELL 1	Y	Photocell 1 enabled.
		N	Photocell 1 disabled.
E2	PHOTOCELL 2	Y	Photocell 2 enabled.
		N	Photocell 2 disabled.
E2	EDGE (SEFETY DEVICE)	Y	Edge enabled.
		N	Edge disabled.

TIMES MANAGEMENT

T3 ADDITIONAL TIME

Additional time at the end of the working time (with full force or during deceleration phase according to the settings) that allows to continue the closing movement even if there is wind.

The T3 function is disabled with the sliding configuration.

During the T3 time, the anti-crushing is not active, so the T3 time must start as near as possible to the door stroke.

The limit switch that determines T3 must not be exceeded to maintain the control of the limit switches in case of motion inversion.

TIMES LEARNING PROCEDURE

CAUTION: start with the gate completely closed.

Times are programmed by means of sequences of START pulses.

Select the menu **C21** to enter this procedure. (menu C21 blinking).

The times learning procedure starts by pressing OK (menu C21 Y fixed) then:

1 motor configuration

- START → the leaf starts opening.
- When the leaf arrives at the desired opening position → START → the leaf stops.
- Counting of the pause time in opening starts.
- When the desired pause time has elapsed → START → the leaf starts closing.
- When the leaf arrives at the closing position → START → the leaf stops.
- Now the procedure has finished, the menu C21 reappears blinking (without Y).
- If you want to repeat the operation, press OK.
- If you want to finish the times learning operation and save the data, press ESC as long as the horizontal lines appear on the display.

2 motors configuration

- START → leaf 1 starts opening
- START → leaf 2 starts opening

- When leaf 1 arrives at the desired opening position → START → leaf 1 stops
- When leaf 2 arrives at the desired opening position → START → leaf 2 stops
- Counting of the pause time in opening starts
- When the desired pause time has elapsed → START → leaf 2 starts closing
- START → Leaf 1 starts closing. (phase shift time setting)
- When leaf 2 arrives at the closing position → START → leaf 2 stops
- When leaf 1 arrives at the closing position → START → leaf 1 stops
- Now the procedure is over, the menu C21 reappears blinking (without Y)
- If you want to repeat the operation, press OK
- If you want to finish the times learning operation and save the data, press ESC as long as the horizontal lines appear on the display

WARNING:

During the times self-learning phase, motion always occurs at a non-decelerated speed.

If decelerations are needed, stop the leaves before the stroke, then remember to enable the decelerations option (menu C6) and set the decelerations times (menu H3 and H6).

During the times self-learning phase, the limit switches and the amperometric thresholds are not considered.

The microcontroller does not consider fractions of times of less than 1 second, so the real time is rounded up or down.

The times set following this procedure can be modified later by entering the proper menus and modifying the numeric value.

If the instalment is configured as double sliding, the motors will move as indicated in the procedure with the phase shift in opening and closing.

During normal working, phase shifts are zeroed.

USING THE LIMIT SWITCHES

If the deceleration function is enabled, the limit switches mark the start of the deceleration time. The gate continues the decelerated motion for the time set in menus H3 and H6.

If 2 limit switches are used, the first one starts the deceleration and the second one ends it.

The deceleration, if enabled, will start upon reaching the limit switches and will last for the time H3 and H6 until the second limit switch has been reached, ending the deceleration phase.

Make sure that the times set are higher than the time necessary to reach the limit switch.

If deceleration is not enabled, the limit switches lock the motion.

The additional time T3 and the final opening/closing stroke, if enabled, work even when there are limit switches.

RESET

The simultaneous pressure of the + and – keys for 3 seconds when the writing PASS is displayed will reset all values, and the default settings will be loaded (only the number of performed cycles are still stored).

FLASHING LIGHT SIGNALS SUMMARY

Device	Signal	Effect
Photo 2 intercepted in stand-by after a start command	5 fast flashings	When released, it opens
Edge intercepted in stand-by after a start command	3 slow flashings	Blocked closed door
Edge intercepted in pause after a start command or at closing	3 fast flashes	Blocked open door

UK

Photo 1 test failed at opening	4 fast flashings	Blocked closed door
Photo 1 test failed at closing	4 fast flashings	Blocked open door
TRIAC test failed at opening	4 slow flashings	Blocked closed door
TRIAC test failed at closing	4 slow flashings	Blocked open door
Edge N.C. test failed at opening	3 slow flashings	Blocked closed door
Edge N.C. test failed at closing	3 slow flashings	Blocked open door
Edge 8K2 test failed at opening	2 slow flashings	Blocked closed door
Edge 8K2 test failed at closing	2 slow flashings	Blocked open door
Expired maintenance	1 minute slow flashing with closed door	None

(* If the flashing light setting is with fixed light (C15 d), the blinking is not present but only the fixed switching on.

DEFAULT SETTINGS

• Active parameters type A:

A2 → Y SWING GATE/OVERHEAD DOOR/BARRIER TYPE
A5 → Y 2 MOTORS
A8 → Y AUTOMATIC-CONDOMINIUM USING

• Parameters type C:

C1 → YT GENERAL AND PEDESTRIAN AUTOMATIC CLOSING ENABLED
C2 → N FAST CLOSING DISABLED
C3 → Y PREFLASHING ENABLED
C4 → N SAFETY DEVICES TEST DISABLED
C5 → E1 LIMIT SWITCH ENABLED (single pair)
C6 → N DECELERATIONS DISABLED
C7 → N WATER HAMMER DISABLED
C8 → N FINAL CLOSING STROKE DISABLED
C9 → NC SAFETY DEVICE (EDGE) WITH N.C. CONTACT
C11 → N COURTESY LIGHT DISABLED
C13 → N T3 EXCLUDED
C14 → N IN PEDESTRIAN CLOSING, IT ENABLES COMPLETE OPENING
C15 → Y INTERMITTENT FLASHING LIGHT
C16 → N EXTERNAL CLOCK CONTACT DISABLED
C17 → N EXTERNAL CLOCK CONTACT DISABLED
C18 → N EXTERNAL CLOCK CONTACT DISABLED
C19 → N OLEODYNAMIC BLOCK MAINTENANCE DISABLED
C20 → N PHOTO 1 TEST DISABLED

• Parameters type F:

F1 → 10 MOTOR 1 FORCE

F2	→	05	MOTOR 1 DECELERATION
F5	→	10	MOTOR 2 FORCE
F6	→	05	MOTOR 2 DECELERATION

• **Parameters type H:**

H1	→	25	MOTOR 1 OPENING TIME
H2	→	25	MOTOR 1 CLOSING TIME
H3	→	20	MOTOR 1 DECELERATION TIME
H4	→	25	MOTOR 2 OPENING TIME
H5	→	25	MOTOR 2 CLOSING TIME
H6	→	20	MOTOR 2 DECELERATION TIME
H7	→	5	LEAF 2 PHASE SHIFT IN OPENING
H8	→	5	LEAF 1 PHASE SHIFT IN CLOSING
H9	→	5	PAUSE TIME
H10	→	5	PEDESTRIAN OPENING TIME
H11	→	5	PEDESTRIAN PAUSE TIME
H12	→	0000	NUMBER OF CYCLES
H13	→	0000	INSTALLER CODE
H14	→	xxxx	SOFTWARE VERSION (format: R__xx)
H15	→	0000	NUMBER OF CYCLES DONE

• **Parameters type E:**

E1	→	Y	PHOTOCELL 1 ENABLED
E2	→	Y	PHOTOCELL 2 ENABLED
E3	→	Y	SAFETY DEVICE (EDGE) ENABLED

FINAL CHECKS AND TESTING

Before powering the control unit, run the following tests:

- 1- Check the electrical connections: improper connection may be harmful to both the control unit and the operator.
- 2- Check proper position of the limit switches.

POWER THE DEVICE

- 3- Check that the red LEDs of the normally closed contacts are on and the green LEDs of the normally open contacts are off
- 4- Check that the writing SAF does not appear on the LCD (intercepted or faulty edge).
- 5- Check that the relative LEDs turn off when limit switches work.
- 6- Check that the relative LED turns off when the photocells ray is intercepted.
- 7- Check that the relative LED turns off when the safety devices work.
- 8- Check that the motors are locked and ready to work with the "GATE COMPLETELY CLOSED".
- 9- Remove possible obstacles in the operating area of the gate, then give the command START. At the first command, the equipment starts opening, then check that the motion direction is correct. If not invert the wires in the terminals M1 and/or M2.

UK

BA230 DISPOSAL

Gi.Bi.Di advises recycling the plastic components and to dispose of them at special authorised centres for electronic components thus protecting the environment from polluting substances.

**SIMPLIFIED PROGRAMMING**

- 1- Connect all the connections (wire motors using a 1,5 mm² wire)
- 2- Enter the installation code, and then set the type of function desired from menu A2/A3.
- 3- Set the number of motors used. Menu A4/A5.
- 4- Set the operation mode. Menu A6/A7/A8/A9.
- 5- Go to menu C21, and select «Y» to activate automatic time programming, then press «START» (+ key) (see page 20 "Time learning procedure")
- 6- Go to menu C5 to choose the number of limit switches. We recommend programming a single limit switch when stopping points are present.
- 7- Go to menu C6 to program slowdowns.
- 8- Use the dedicated menus to adjust each time parameter.
- 9- Press «ESC» to exit programming.
- 10- Check whether the force used by operators on the gate is either sufficient or excessive. Go to menu F to adjust, if necessary.

CE Declaration of conformity

The manufacturer:

GI.BI.DI. S.r.l.

Via Abetone Brennero, 177/B,
46025 Poggio Rusco (MN) ITALY

Declares that the products:

ELECTRONIC CONTROL UNIT BA230

are in conformity with the following CEE Directives:

- **LVD Directive 2006/95/CE and subsequent amendments;**
- **EMC Directive 2004/108/CE and subsequent amendments;**

and that the following harmonised standards have been applied:

- **EN60335-1**
- **EN61000-6-2, EN61000-6-3**

Date 23/03/09

Managing Director
Oliviero Arosio



■ a **BANDINI INDUSTRIE** company



ISO 9001 Cert. N. 0079

GIBIDI

GI.BI.DI. S.r.l.

Via Abetone Brennero, 177/B
46025 Poggio Rusco (MN) - ITALY
Tel. +39.0386.52.20.11
Fax +39.0386.52.20.31
E-mail: comm@gibidi.com

Numero Verde: 800.290156



www.gibidi.com